

*thermo
hauser*



FRESH TO THE FINISH

**TRANSPORT AND INSULATED BOXES
FOR SUSTAINABLE FOOD LOGISTICS**

WELL RECEIVED!

EFFICIENT FOOD LOGISTICS

THE CHALLENGE

The biggest challenge in food logistics is safely transporting the goods to their destination in fresh condition. External influences such as extreme temperatures, dust, pollen and rain can affect the quality of the food during transportation. Delays and lack of refrigerated lorries etc. can also jeopardise a secure supply chain. In addition, many fresh and processed foods require special „travel conditions“ such as air circulation, temperature stability or refrigeration.

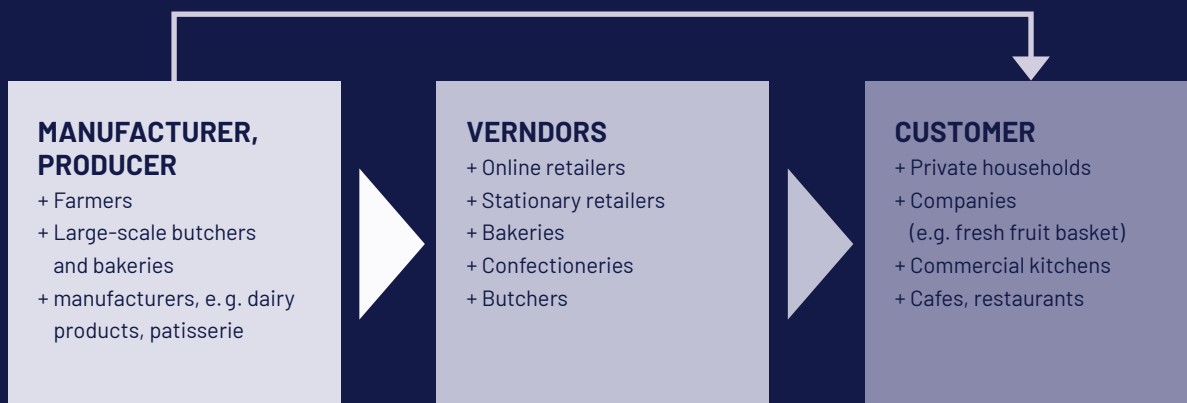

OUR SOLUTION FOR YOU

To make sure your perishable goods arrive at their destination in top condition despite all the challenges, thermohauser offers a wide selection of insulated and non-insulated transport containers that are perfectly designed to meet your products' specific needs. So you can avoid unnecessary food spoilage and waste. This is a crucial foundation for a sustainable business.

If our standard range doesn't meet your requirements, that's no problem. Our product development team always has a close eye on the market and is hard at work on innovative approaches. We would be delighted to collaborate more closely with you to create a highly customised solution that fulfils your requirements.

Tried-and-tested transportation or new, customised solutions, with thermohauser products you get sustainable goods handling combined with excellent customer satisfaction.



INSULATED TRANSPORT

FOR TEMPERATURE-SENSITIVE FOOD: THERMOBOXES MADE FROM EXPANDED POLYPROPYLENE

The insulated boxes from thermohäuser are ideal for getting your fresh, perishable creations to their destination safely and in impeccable condition, even if transported over long distances, or for considerable periods of time, or if exposed to extreme temperatures such as heat or frost.

The low weight of these EPP boxes makes them the ideal transportation accessories. They are made from expanded polypropylene, which originates from the automobile sector

and is known for its durability, elasticity and resistance to breaking. Ideal for transporting products that are subject to specific hygiene and safety regulations.

The thermohäuser insulated boxes are fully enclosed and designed with a lid to protect your goods against undesirable external influences. So the food arrives at its destination safely protected from pollen, dust, weather conditions, pests and other external factors. EPP is also odourless and tasteless.

EPP transport boxes are designed for a long service life and regular use in the food sector, including at a range of different temperatures.



BREAK-RESISTANT

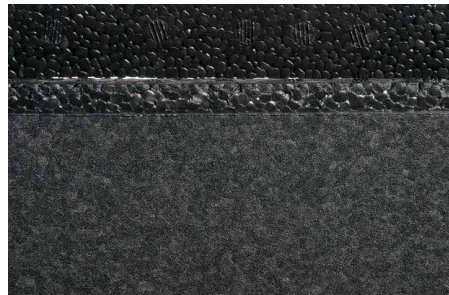

INSULATING



SUSTAINABLE THROUGH RECYCLING



SAFE FOR TRANSPORT



LIGHT WEIGHT



DISHWASHER-PROOF

INSULATED TRANSPORT

Every area of application has different requirements. thermohauser offers a comprehensive range of transport and storage solutions for food products including the right accessories. Choose from various basic formats and sizes!



GOOD TO KNOW

Ideally, the size of the insulated boxes should be tailored to fit the contents as precisely as possible; in other words, the products should fit as snugly as possible. The less empty space there is in the box, the more stable the temperature will be.

EPP BOXES

- + Material: EPP, highly insulating
- + Hygienic
- + Easy to clean
- + Waterproof inside surface
- + Perfectly insulation in a temperature range from -40°C up to $+120^{\circ}\text{C}$
- + Boxes with the same base size can be stacked



EPP BOX FOR EURONORM CONTAINERS

THIS BOX FITS PERFECTLY INTO EURONORM CONTAINERS E2 / E3, WHICH ARE PART OF THE CLASSIC BASIC EQUIPMENT IN THE BUTCHERY SECTOR.

The combination of box and Euronorm container ensures that meat, fish, vegetables and other foodstuffs can be transported from A to B and stored temporarily in a way that ensures food hygiene and a stable temperature, while also being logistically efficient. A thermohauser box which was the result of a customised process for a particular butcher's business.



- + Fits perfectly in stacking containers of Euronorm sizes E2 and E3
- + Completely recyclable
- + Waterproof inner surface
- + Radii inside for easy cleaning
- + Carrying handles and additional under grip handles
- + Two handles for easy removal of the lid
- + Light weight and break-resistant
- + Dishwasher-proof

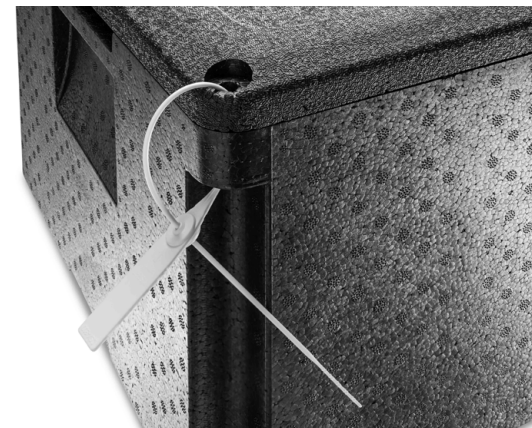

GOOD TO KNOW

Added security: specially designed holes for sealing! Your guarantee that the box will only be opened again when it reaches its destination.

PRODUCT NR.	VERSION
8300054398	Thermobox for Euronorm container size E2, usable height 11,5 cm
8300054393	Thermobox for Euronorm container size E3, usable height 21,5 cm

EPP BOX MULTI MAX

STACKING AND TURNING XXL!

When it comes to maximising space requirements, the Multi Max thermobox is the best choice. One of the key features of this miraculously space-saving design is its very large base area. You can also get a separately available and specially designed top frame and/or a second box, which is added as a lid section, allowing you to maximise the height on offer. This is the ideal box if you need plenty of space and the very highest quality.

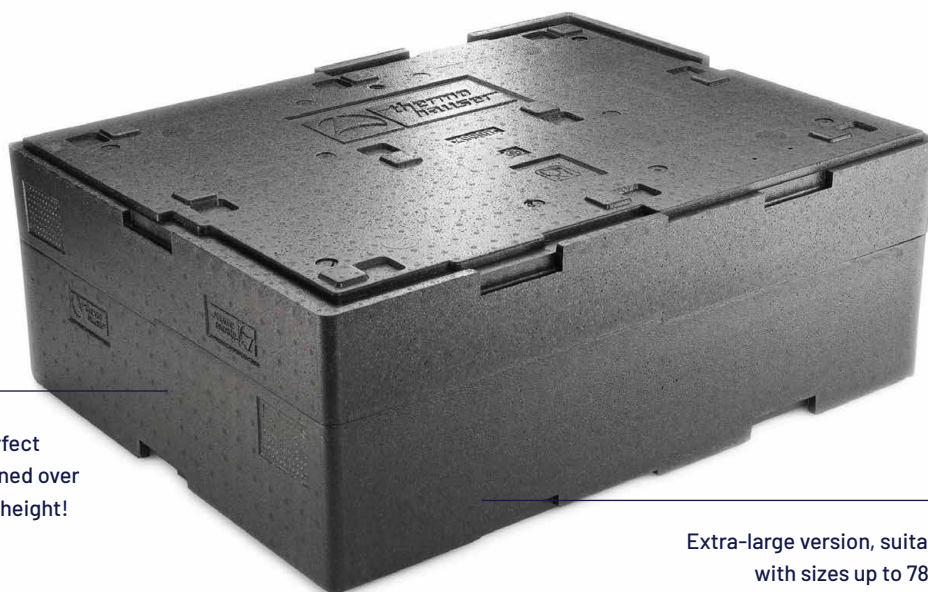

The top box serves as perfect lid for the one below – turned over even to double the inside height!

Extra-large version, suitable for trays with sizes up to 78,0 x 58,0 cm



- + Box without lid
- + Outside dimensions cm (l x w): 89,0 x 68,5
- + Inside dimensions cm (l x w): 80,0 x 60,0

PRODUCT NR.	VERSION
4000249980	Thermobox , usable height 8 cm, capacity 48 litres
4000249982	Thermobox , usable height 15 cm, capacity 87 litres

EPP BOX FOR GASTRONORM

THESE BOXES ARE SUITABLE FOR ALMOST ALL PURPOSES. THEY ARE VERY VERSATILE. THE BOX CAN BE FITTED WITH SEVERAL GN CONTAINERS.



- + Waterproof inside surface
- + Easy loading and unloading due to the recessed space on the long sides and corners
- + Highest quality outer surface
- + Opening lid from the corners
- + Rigid or flexible labels for easy product identification
- + Outside dimensions cm (l x w): 60,0 x 40,0
- + Inside dimensions cm (l x w): 53,5 x 34,0

COOLING FRAME

- + Incl. thermometer for ongoing temperature control from the outside
- + Cooling from above with up to 6 ice packs (separately available)



COOLING FRAME FOR THERMOCELL

- + Speziell für den Einsatz von ThermoCell Kühlakkus entwickelt
- + Cooling from above with 2 ThermoCell ice packs (separately available)

PRODUCT NR.	VERSION
8300040454	Thermobox usable height 8,5 cm, capacity 15 litres
8300040456	Thermobox usable height 12 cm, capacity 21,5 litres
8300040457	Thermobox usable height 17 cm, capacity 30,5 litres
8300040458	Thermobox usable height 22 cm, capacity 39,5 litres
8300040459	Thermobox usable height 27 cm, capacity 49 litres
8300040460	Cooling frame for thermobox Gastronorm
8300040460	ThermoCell cooling frame for thermobox Gastronorm

*This box series is explicitly recommended by the Bundesverband der Lebensmittelkontrolleure e.V. (Federal Association of Food Inspectors)! When used properly, the boxes contribute to „ensuring food safety“ when transporting food (certificate, 2023).

EPP BOX IN LARGE SIZE

UNIVERSALLY APPLICABLE. IDEALLY SUITED FOR BAKERIES AND PASTRY SHOPS. ADAPTED TO THE STANDARD TRAY SIZE 60,0 X 40,0 CM.



- + Waterproof inside surface
- + Easy loading and unloading due to the recessed space on the long sides and corners
- + Highest quality outer surface
- + Ergonomic handles
- + Opening lid from the corners
- + Rigid or flexible labels for product identification
- + Outside dimensions cm (l x w): 69,5 x 49,5
- + Inside dimensions cm (l x w): 62,5 x 43,5
- + Perfect to be used by bakeries and pastry shops, designed to transport baking trays with the dimension 60,0 x 40,0 cm



COOLING FRAME

- + Incl. thermometer for ongoing temperature control from outside
- + Cooling from above with up to 6 ice packs (separately available)

PRODUCT NR.	VERSION
8300049839	Thermobox usable height 12 cm, capacity 33 litres
8300049840	Thermobox usable height 16 cm, capacity 44 litres
8300049841	Thermobox usable height 20 cm, capacity 55 litres
8300049842	Thermobox usable height 26 cm, capacity 70 litres
8300049843	Thermobox usable height 30 cm, capacity 82 litres
8300049844	Cooling frame for thermobox

*This box series is explicitly recommended by the Bundesverband der Lebensmittelkontrolleure e.V. (Federal Association of Food Inspectors)! When used properly, the boxes contribute to „ensuring food safety“ when transporting food (certificate, 2023).

EPP BOX IN SMALL SIZE

THE SMALL DESIGN, E.G. FOR AN OPTIMISED COLD CHAIN FOR SMALLER FOODSTUFFS SUCH AS FISH, DAIRY PRODUCTS AND DESSERTS OR FOOD DELIVERIES TO PRIVATE HOUSEHOLDS.

- + square size and lid with ventilation slots
- + Incl. studded bottom for better air circulation

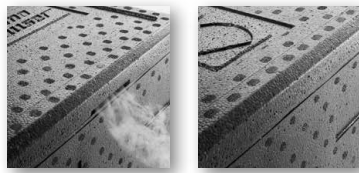

- + Small size for an optimised cold chain of smaller foodstuffs
- + Due to the small size the temperatur of e.g. cold desserts, fish, and dairy products can also be optimally maintained.
- + Outside dimensions cm (l x w): 41,0 x 41,0
- + Inside dimensions cm (l x w): 35,0 x 35,0
- + Boxes with the same base size can be stacked.



ADDITIONAL STACKING FRAME

- + 10 cm more effective depth per stacking frame



SUITABLE COOLING LID

- + Incl. thermometer
- + Cooling from above with up to 5 ice packs (separately available)
- + For transportation of cakes, pies and other baked creation

PRODUCT NR.	VERSION
4000249708	Thermobox usable height 10 cm, capacity 12,5 litres
4000249718	Thermobox usable height 17,5 cm, capacity 21,5 litres
4000249778	Thermobox usable height 20,5 cm, capacity 25 litres
4000249728	Thermobox usable height 26,5 cm, capacity 32,5 litres
4000249738	Thermobox usable height 30,5 cm, capacity 37,5 litres
4000249748	Thermobox usable height 34 cm, capacity 41,5 litres
8300038800	Stacking frame for thermobox
8300029750	Cooling lid for thermobox

NOT INSULATED PLASTIC CONTAINER

CLASSIC TRANSPORT AND BRILLIANT ORGANISATION – STACKING CONTAINERS ARE PRACTICAL ACCESSORIES.

These products come into play if food does not need to be refrigerated or if air circulation is important, for example. In these situations, these plastic containers are the perfect, versatile accessory for universally applicable transportation and storage.

Depending on requirements, the containers are available with closed or perforated bases/sides.

Practical, robust, durable, sturdy, stackable and high-quality – these are key characteristics in all thermohäuser stackable containers.

Needless to say, they also comply with applicable hygiene regulations and are odourless and tasteless.

Thanks to the smooth finish on all containers,

cleaning is very easy and produces reliable results.

The lightweight design means the containers are easy to handle and can be stacked for space-saving storage.

The combination of insulated and plastic boxes can also be useful for deliveries.

Customers benefit from a variety of shapes and sizes.



- + Good handling thanks to open recessed grips
- + Robust, durable, stable
- + Stackable by type
- + Conform to the applicable hygiene regulations
- + Some formats can be combined with EPP boxes
- + Easy to clean thanks to smooth wall finish
- + Low dead weight
- + With closed or meshed bottom / siding

STACKING CONTAINERS, MESHED

THANKS TO THE PERFORATED BASE AND SIDES, THIS STACKING CONTAINER ENSURES OPTIMUM AIR CIRCULATION.

Ideal conditions for food with residual moisture, for example. Other plus points: reinforced struts in the sides ensure excellent stability, rounded recessed grips offer convenient carrying options, a transparent design makes it easy to see what's inside.

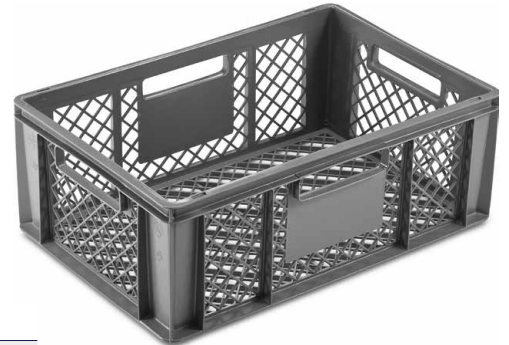

PRODUCT NR.	VERSION
5000146418	Stacking container usable height 11,5 cm, capacity 23 litres
5000146428	Stacking container usable height 16,5 cm, capacity 33 litres
5000146338	Stacking container usable height 21,5 cm, capacity 43 litres
5000146448	Stacking container usable height 31,5 cm, capacity 63 litres
5000146458	Stacking container usable height 41,5 cm, capacity 83 litres

- + Material: HDPE
- + Colour: grey
- + Outside dimensions cm (l x w): 60,0 x 40,0
- + Inside dimensions cm (l x w): 56,5 x 36,5
- + Unit: 1 piece

STACKING CONTAINERS, CLOSED

THESE FUNCTIONAL CONTAINERS ARE HIGHLY DURABLE: THEY CAN BE USED IN COLD ROOMS AND FOOD AREAS.

Important: e.g. when transporting raw meat and charcuterie. Robust handles with rounded edges ensure safe and ergonomic handling. The sealed sides of the containers ensure nothing can leak out.



ARTIKEL-NR.	VARIANTE
5000146508	Stacking container usable height 11,5 cm, capacity 23 litres
5000146538	Stacking container usable height 16,5 cm, capacity 33 litres
5000141828	Stacking container usable height 21,5 cm, capacity 43 litres
5000146578	Stacking container usable height 31,5 cm, capacity 63 litres
5000146588	Stacking container usable height 41,5 cm, capacity 83 litres
5000141988	Lid for stacking container

- + Material: HDPE
- + Colour: grey
- + Outside dimensions cm (l x w): 60,0 x 40,0
- + Inside dimensions cm (l x w): 56,5 x 36,5
- + Unit: 1 piece

STACKING CONTAINERS, CLOSED

THESE STACKING CONTAINERS IN NATURAL WHITE ENSURE SAFE TRANSPORTATION AND EXCELLENT ORGANISATION OF RAW MATERIALS AND INTERMEDIATE PRODUCTS IN STOREROOMS, WAREHOUSES AND KITCHENS.

They are designed with smooth surfaces for excellent hygiene, and an ergonomic stacking rim around the top of each box. Whether it's for raw materials, pre-prepared food, or non-food items, the stacking containers are ideal accessories for organising operational activities. The sealed sides of the containers ensure nothing can leak out.



ARTIKEL-NR.	VARIANTE
5000141312	Stacking container 59 x 39 cm, white , usable height 16 cm, capacity 30 litres
5000141322	Stacking container 59 x 39 cm, white , usable height 21 cm, capacity 40 litres
5000141332	Stacking container 59 x 39 cm, white , usable height 31 cm, capacity 60 litres
5000141342	Lid for stacking container 59 x 39 cm, white

- + Material: HDPE
- + Colour: natural white
- + Leak-proof
- + Hygienic smooth surface
- + Unit: 1 piece

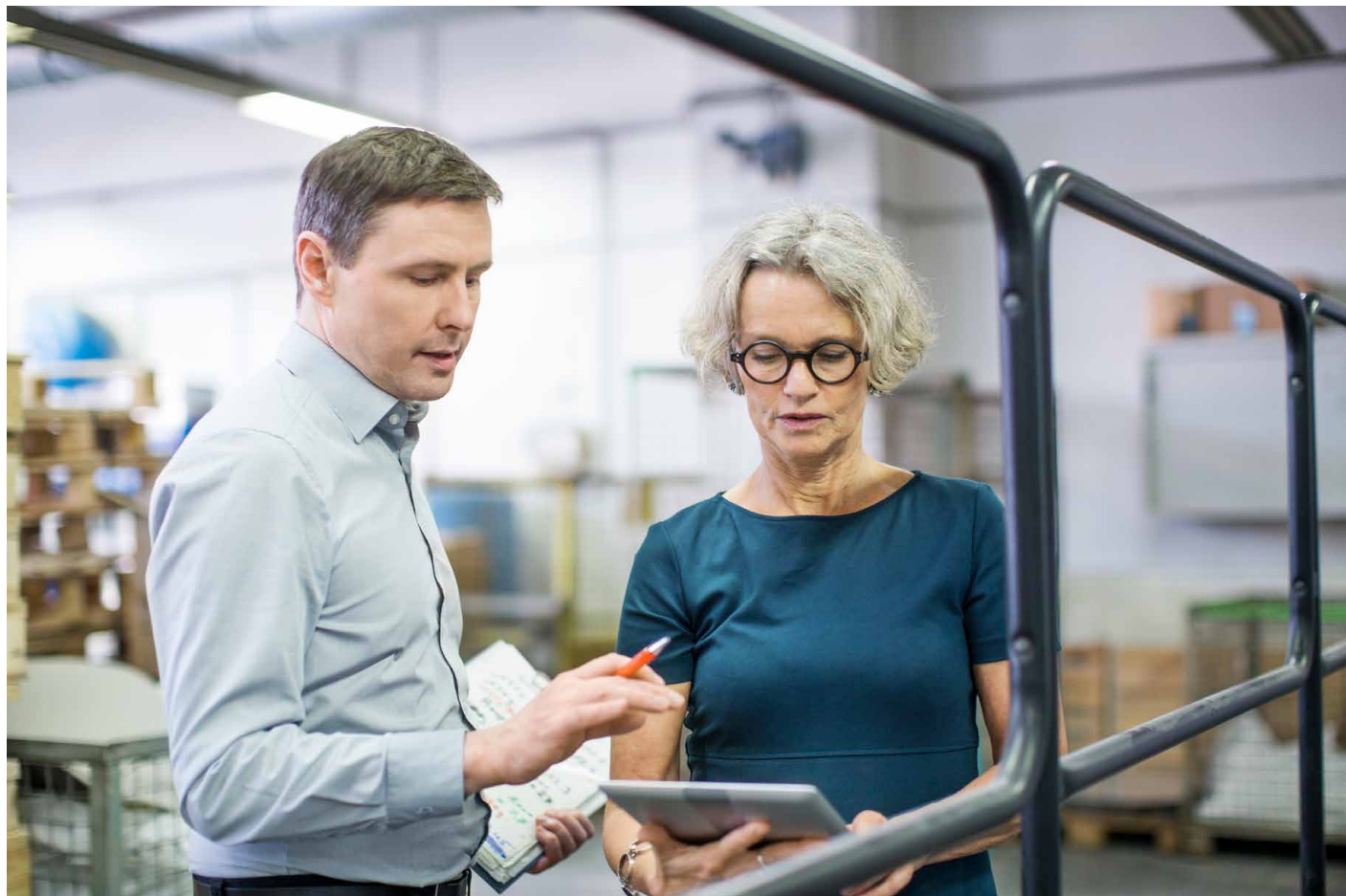

SUITABLE ACCESSORIES

**MATCHING ACCESSORIES ARE ALSO AVAILABLE FOR ALL BOXES.
YOUR CONTACT AT THERMOHAUSER WILL BE HAPPY TO ADVISE YOU.**



INLAY FOIL

Made of blue polyethylen. For more hygiene and less cleaning effort simply slip the foil into the box. Suitable for all standard boxes.



THERMOCELL GN 1/2

The ThermoCell series consists of seven different pack types. Each is specially developed for a specific temperature range. Whether for frozen and chilled products or hot food: with the right pack, the DIN specifications are met and products will reach their destination at the right temperature.



DOLLIES

Easy to move and energy saving.
With 2 fixed and 2 steering castors each.



ICE PACK

Weighing less than 500 g, the professional ice pack offers excellent additional cooling thanks to its extra strong gel filling. It releases cold evenly to its surroundings for hours.

PRODUCT NR.	VERSION
8300064117	ThermoCell ice pack Frozen (-21°C) GN 1/2, dark blue, -18 up to -10°C
8300064118	ThermoCell ice pack Cold (-12°C) GN 1/2, blue, -9 up to -3°C
8300064119	ThermoCell ice pack Sensitive (-6°C) GN 1/2, light blue, -3 up to +4°C
8300064120	ThermoCell ice pack Fridge (-3°C) GN 1/2, translucent, 0 up to +8°C
8300064121	ThermoCell heat pack Ambient GN 1/2, yellow, 10 up to 20°C
8300064122	ThermoCell heat pack Hot GN 1/2, orange, 65 up to 75°C
8300064122	ThermoCell heat pack Hot Premium GN 1/2, red, 65 up to 85°C
4000185088	Ice pack 17,5 cm x 9 cm x 3 cm
5000142885	Dollies for containers up to size 60,0 x 40,0 cm Stainless steel, weight approx. 4,3 kg
5000142915	Dollies für Behälter up to size 60,0 x 40,0 cm Plastic, red, weight approx. 2,7 kg
5000142765	Dollies for containers up to size 70,0 x 50,0 cm
8300052516	Inlay foil for thermoboxes
8300041632	Security seal



SECURITY SEAL

Tamper-proof seal to protect against unauthorized access. After removing the seal from the surface the lettering "VOID OPEN" appears. After removing the seal is destroyed and not reusable. Heat resistance: -30 °C up to +80 °C.



CUSTOM MADE SOLUTIONS

LARGER, SMALLER OR SIMPLY SOMETHING DIFFERENT?

We offer individual customisation for your needs. Many of the items in our range can easily be refined to meet your requirements. Thanks to a variety of technical design options, we can work with you to create customised transport solutions. Together, we take a close look at your logistics chain and your products in order to develop a tailor-made solution.

Take advantage of our expertise and make your ideas a reality.

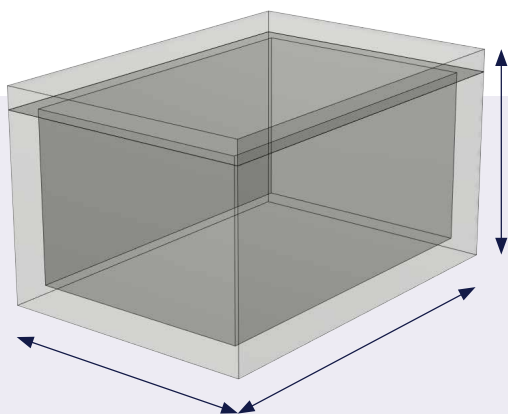

**VARIABLE
TO SUIT YOUR
NEEDS**

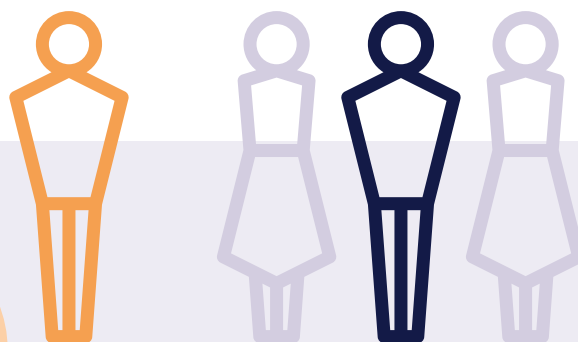

THE PROCESS

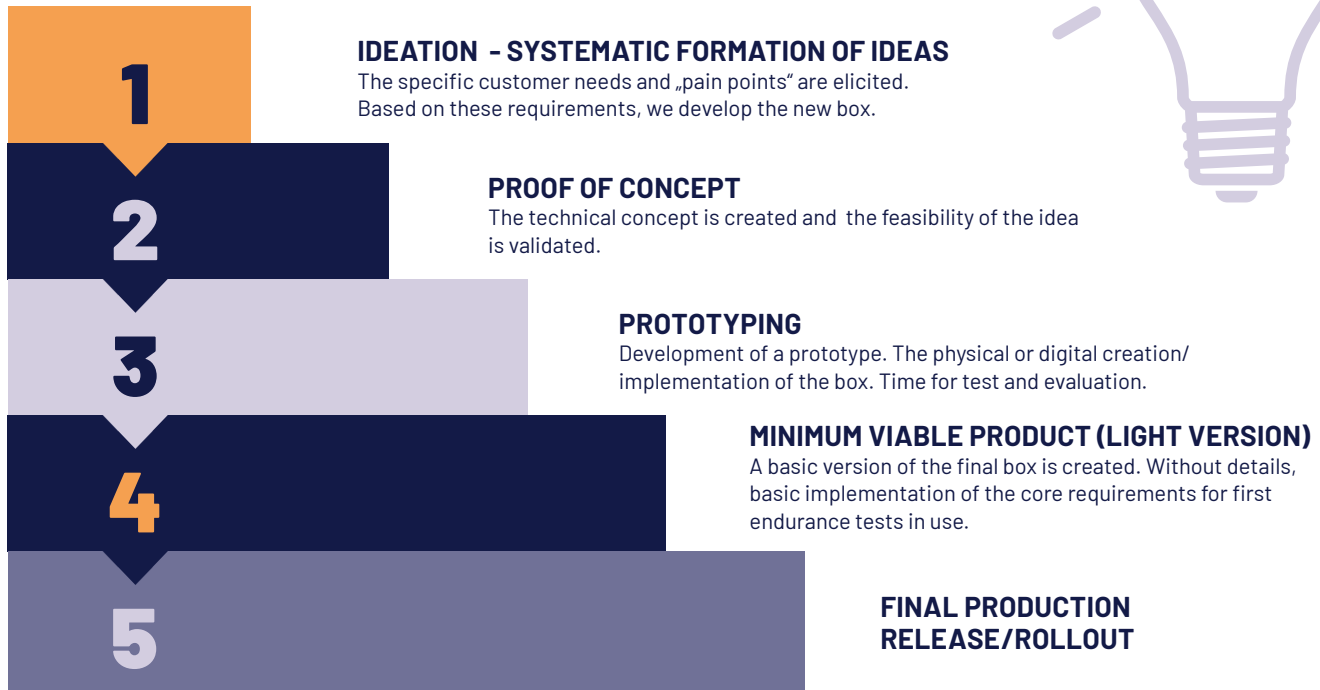

PACKAGING FOR YOUR BRAND

Branded packaging offers enhanced recognition value and can strengthen customer loyalty. Your logo also has a functional benefit: it can speed up the allocation of transport containers in the distribution cycle.

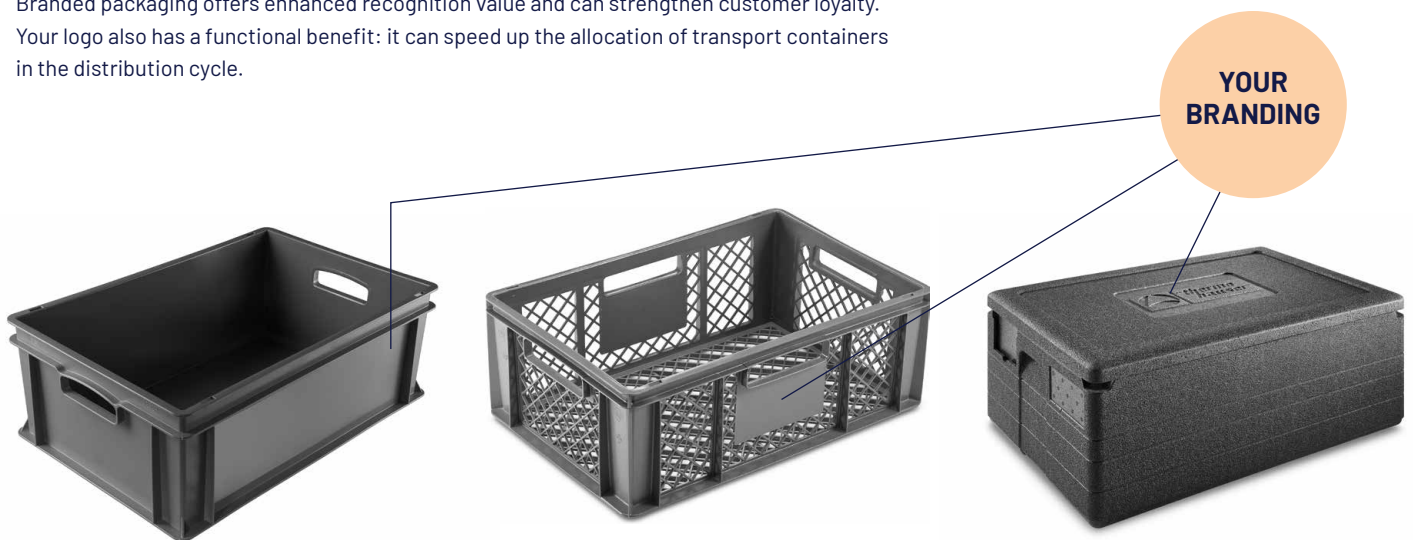

THERMOHAUSER'S CUSTOMISED PROCESS: MAKE SURE YOUR PRODUCTS REACH YOUR CUSTOMERS SAFELY AND WELL-PACKAGED.

Any questions?
We would be delighted to help!

THERMOHAUSER GMBH
BLEICHEREISTRASSE 28
73066 UHINGEN
GERMANY

PHONE: +49 7161 93 84 - 0
EMAIL: INFO@THERMOHAUSER.DE
WWW.THERMOHAUSER.DE